

BarnDoorStrike 1

PAGE

Installation Instructions for CAVILOCK Barn Door Strike

Tools Required:

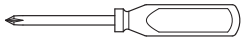

NO. 2 PHILLIPS SCREWDRIVER

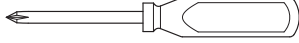

NO. 3 PHILLIPS SCREWDRIVER

Parts List

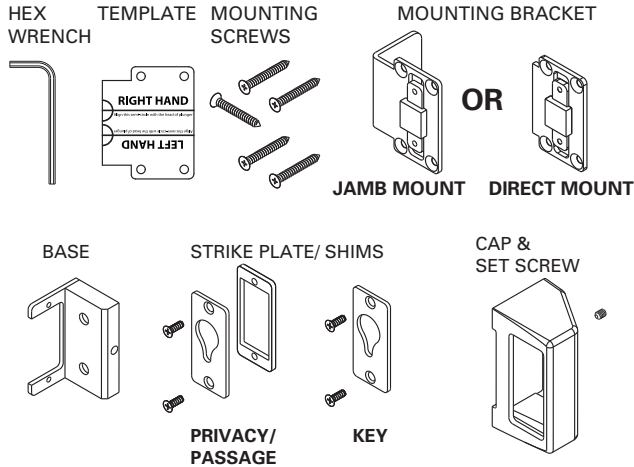

Installation

1. Install mounting bracket:

Use template to drill pilot holes for mounting screws. Align center of semicircle on template with head of plunger.

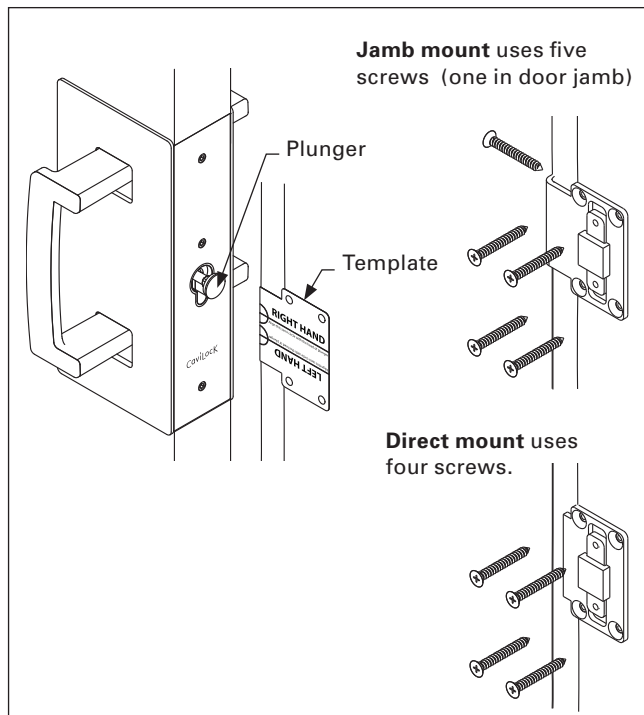

2. Install Base:

Install base to mounting bracket. Note: vertical adjustability ("I SLIDE"). Do not tighten screws yet.

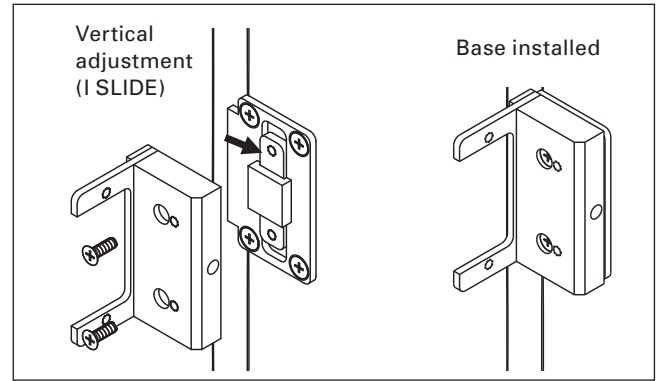

3. Install Magnet:

Use back two holes for flush striker (Passage/Privacy). Use front holes for recessed striker (Key Locking).

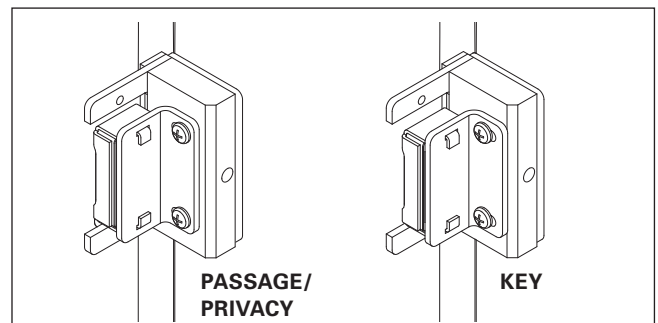

4. Temporarily install the strike.

Install strike and shim for Privacy/Passage. Install strike only for Key.

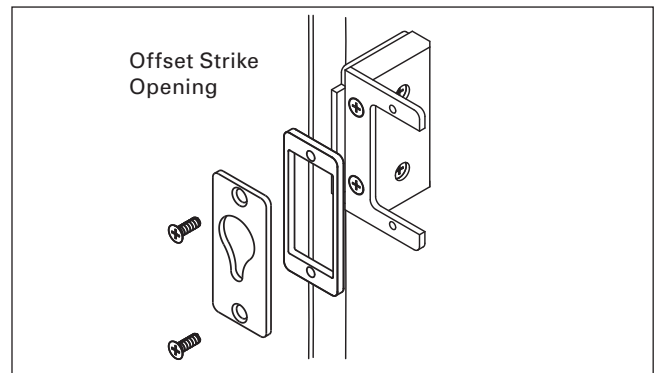

Note: strike is offset and reversible for best fit. Make vertical adjustment if needed and tighten screws.

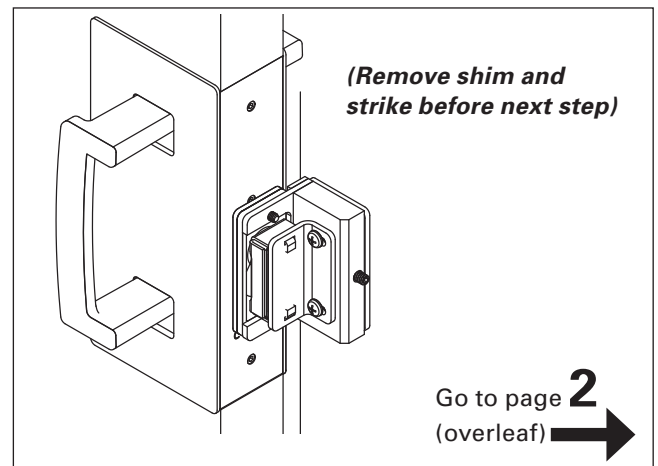

Installation (continued)

5. Install cap.

Tighten set screw into divot in the back of the base.
(Use 3/32" hex wrench)

Note: installation of the shims and strikes completes the assemble/retention of the cap.

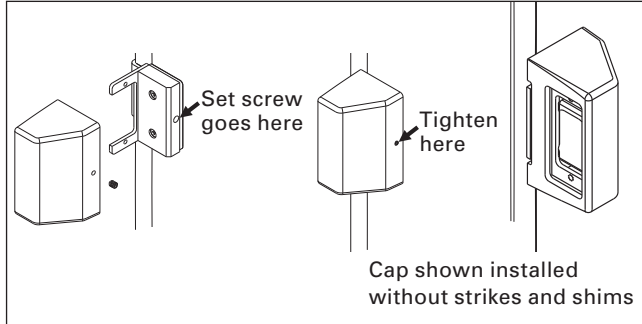

6. Install shims and strike.

Note: Strike opening is offset and reversible for best fit.

Passage/ Privacy: Install shim and strike.

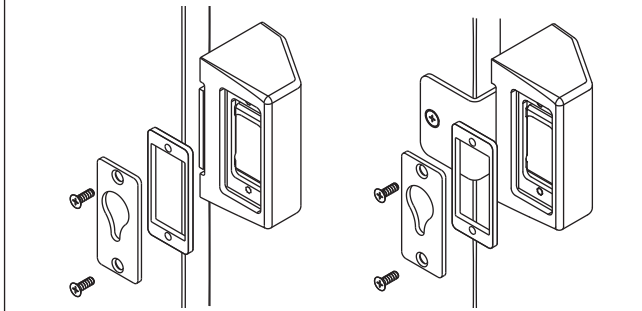

Key Locking: Install strike.

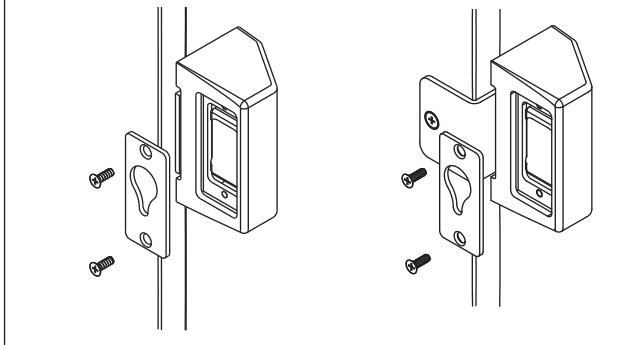

Strike is offset and reversible

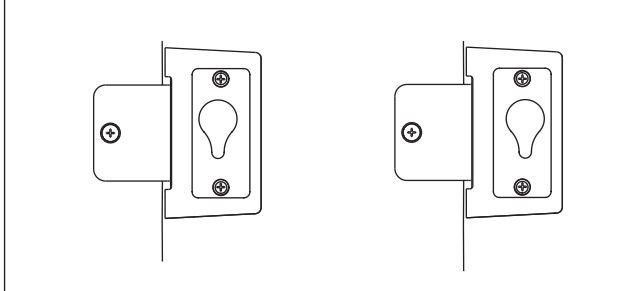

Drawings are not to scale.

7. Important: set barn door rail stop.

Close door and adjust stop.

Track stop must be set to hit roller before door makes contact with the strike. The amount varies with each manufacturer and should be thoroughly tested.

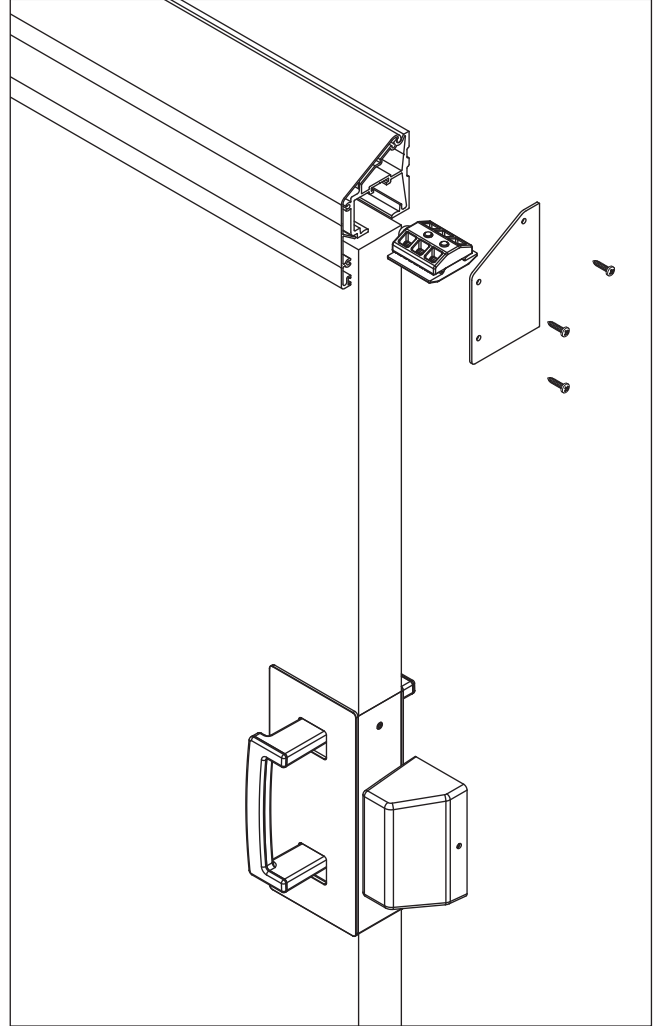

CavitySliders™

CaviLock®

548 Finney Ct
Gardena
CA 90248

T (888) 466 0030
F (310) 769 5824
www.cavitysliders.com

© Cavity Sliders USA Inc. **CAVILOCK® BARN DOOR STRIKE®**

(O.D. 2018) 61336 - 02.2019

All copyright and other property in this document is reserved by Cavity Sliders USA Inc. Details and specifications are subject to change without notice. Whilst all care is taken to ensure the accuracy of all information, no responsibility will be accepted for any errors or omissions. ® CAVILOCK is a Registered Trademark. Patents pending.